

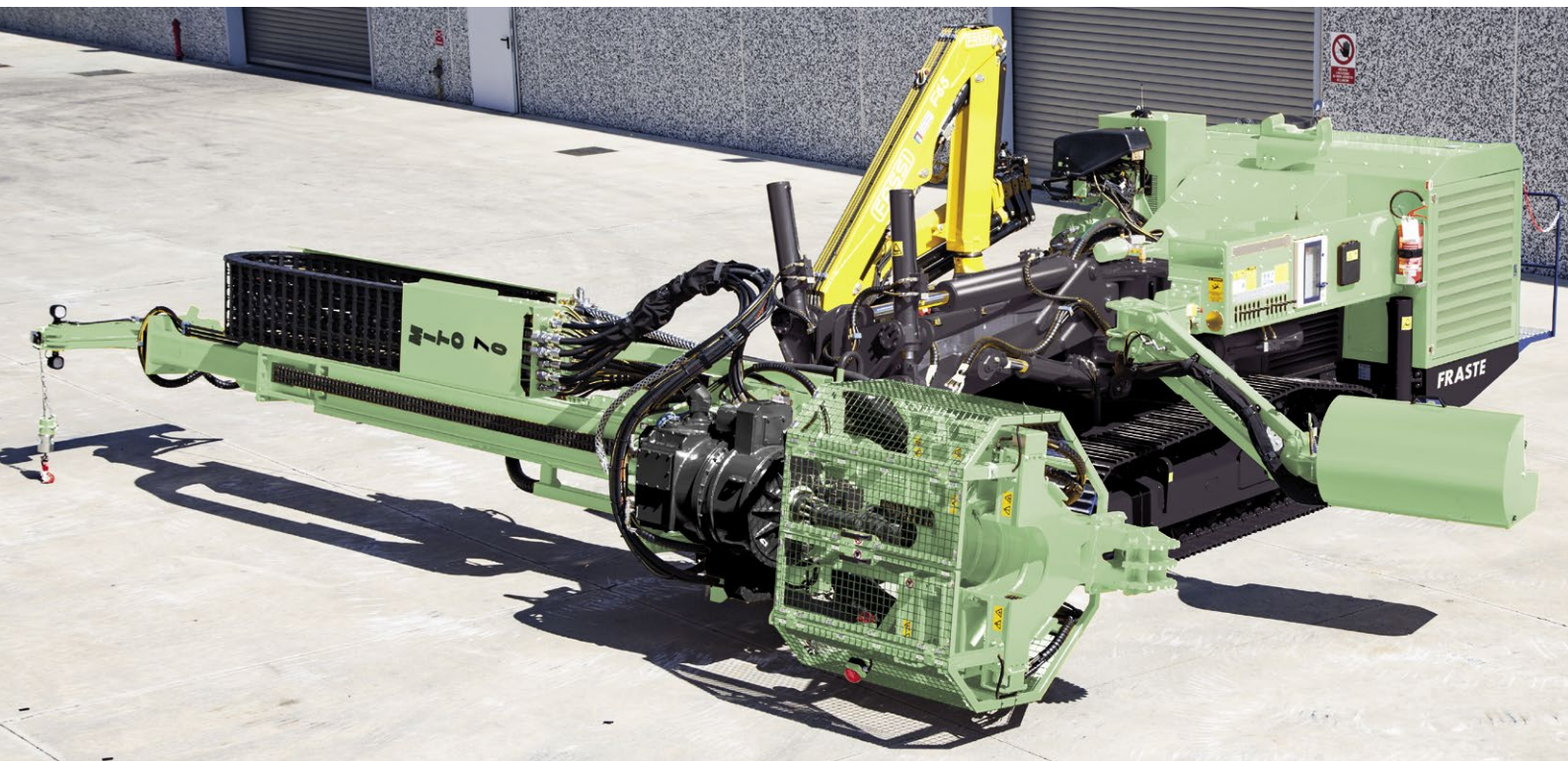



DRILLING RIGS
SINCE 1964



MITO 70



 **MITO 70** perforatrice idraulica per Fondazioni, brandeggiabile e adatta a diverse applicazioni come Ingegneria Civile, Micropali, Ancoraggi, Jet Grouting e Consolidamenti. Manovrabilità, Affidabilità e Produttività fanno della **MITO 70** una perforatrice molto versatile, grazie anche alle innovative tecniche di progettazione ed allo speciale sistema di articolazione **Fraste**. Componentistica ed impiantistica hi-tech, motore ad elevate prestazioni e vasta scelta di accessori e optional: teste di rotazione per usi diversificati, martelli idraulici, doppia testa, pompe acqua/fanghi, caricatori aste/tubi di rivestimento e radiocomando; il tutto per operare in qualsiasi tipo di terreno sia a rotazione sia a roto-percussione.

 Foreuse hydraulique pivotante **MITO 70** pour Fondations, qui s'adapte aux différentes applications dans le domaine du Génie Civil, Micropieux, Ancrages, Jet Grouting et Consolidations. Manœuvrabilité, Fiabilité et Productivité rendent la foreuse **MITO 70** très versatile, grâce à des solutions techniques innovantes et au système d'articulation spécial **Fraste**. Composants et système hydraulique hi-tech, moteur très puissante et large choix d'équipements et d'optionnels : têtes de rotation pour opérations de forage diversifiées, marteaux hydrauliques, systèmes de double tête de rotation, pompes à l'eau boues, systèmes de chargement des tiges de forage/tuyaux de revêtement et radiocommande, pour opérer dans tout type de sol soit avec rotation soit avec roto-percussion.

 **MITO 70** Foundation hydraulic drilling rig, multipurpose, suitable for Civil Engineering, Micropiles, Anchoring, Jet Grouting, Consolidations and other. Maneuverability, Reliability and Productivity make the **MITO 70** an highly versatile drilling rig, thanks to new innovative design techniques and the special **Fraste** articulation system. Hi-tech components and hydraulic system, powerful engine and wide range of equipment and optional: rotary heads for different drilling scopes, hydraulic hammers, double head systems, water/ mud pumps, drill pipes/casing loading systems, and radio control system, in order to operate in any type of ground both with rotation and roto-percussion system.

 Schwenkbare und hydraulische **MITO 70** Fundament-Bohrmaschine, geeignet für verschiedene Anwendungen im Tiefbau, Mikropfähle, Verankerungen, Jet Grouting und Sicherungsarbeiten. Lenkbarkeit, Zuverlässigkeit und Produktivität machen **MITO 70** dank dem Einsatz innovativer technischer Lösungen und dem besonderen **Fraste** Gelenksystem zu einem extrem anpassungsfähigen Bohrergerät. High-Tech-Komponenten und Hydraulikanlage, leistungsstarke Motor gewährleistet und zahlreiche Zubehörteile und Optional: Drehköpfe für diversifizierte Bohrungen, Schlaghammer, Doppelkopfsysteme, Schlamm- und Wasserpumpen, Bohrstangen/ Verrohrungen Ladungssysteme und das Fraste Funkfernsteuersystem; das Ganze, um bei jeder Bodenbeschaffenheit sowohl mit Drehbohrung wie mit Roto-Perkussion vorzugehen.

Innovation, Power, Versatility.



 **MITO 70** perforadora hidráulica para Fundaciones, con rotación y adecuada para diferentes aplicaciones en la Ingeniería Civil como Micropilotes, Anclajes, Jet Grouting y Consolidación. Maniobrabilidad, Fiabilidad y Productividad hacen de la **MITO 70** una perforadora altamente versátil, gracias también a las soluciones técnicas innovadoras y al especial sistema de articulación **Fraste**. Componentes y sistema hidráulico hi-tech, motor muy potente y amplia gama de accesorios y opcional: cabezales de rotación para usos diversificados, martillos hidráulicos, sistemas de doble cabezal, bombas para agua y lodo, cargadores de varillas/tuberías casing y sistema de radiocomando; todo eso para operar en cualquier tipo de suelo tanto a rotación como con rotopercusión.



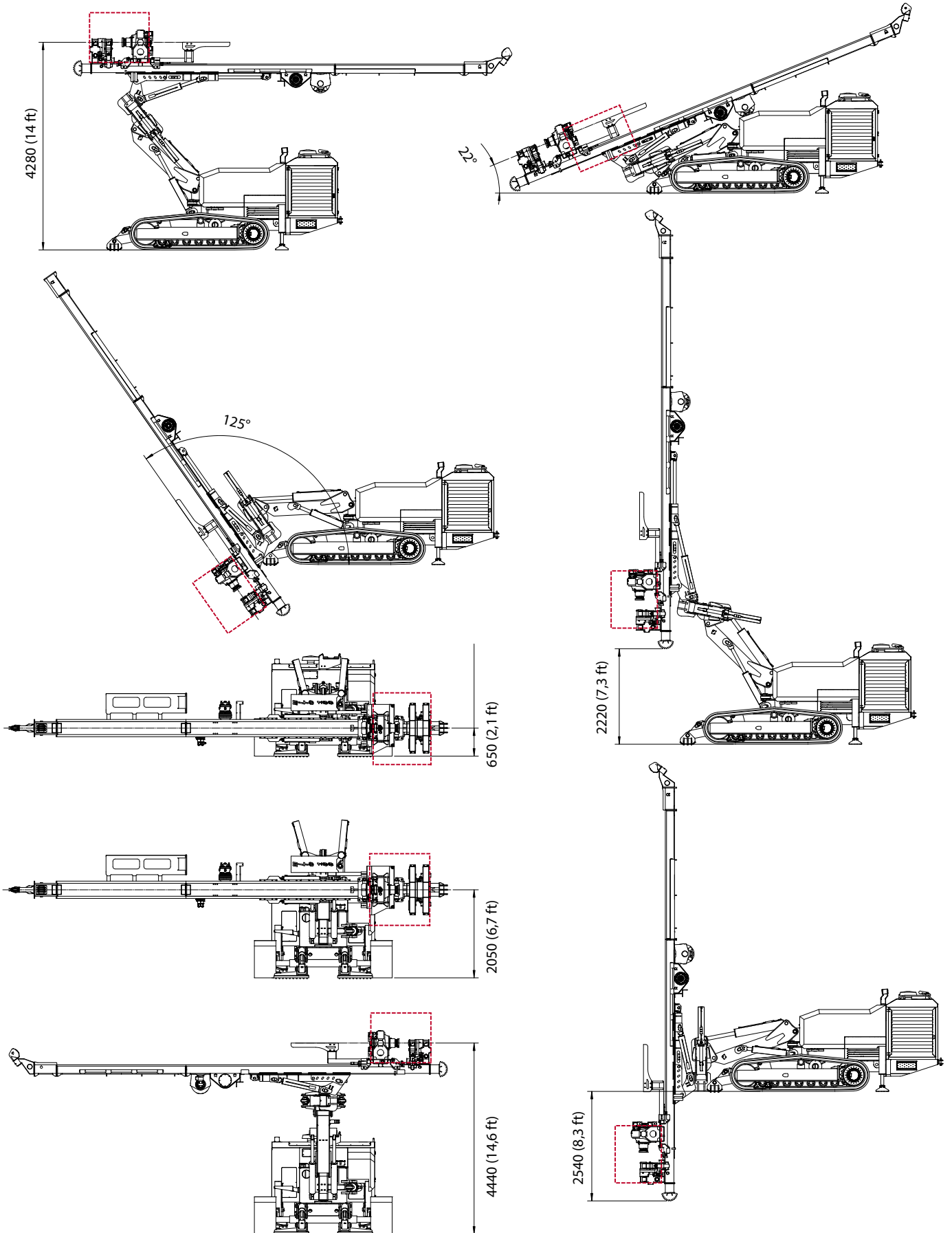

Dimensions

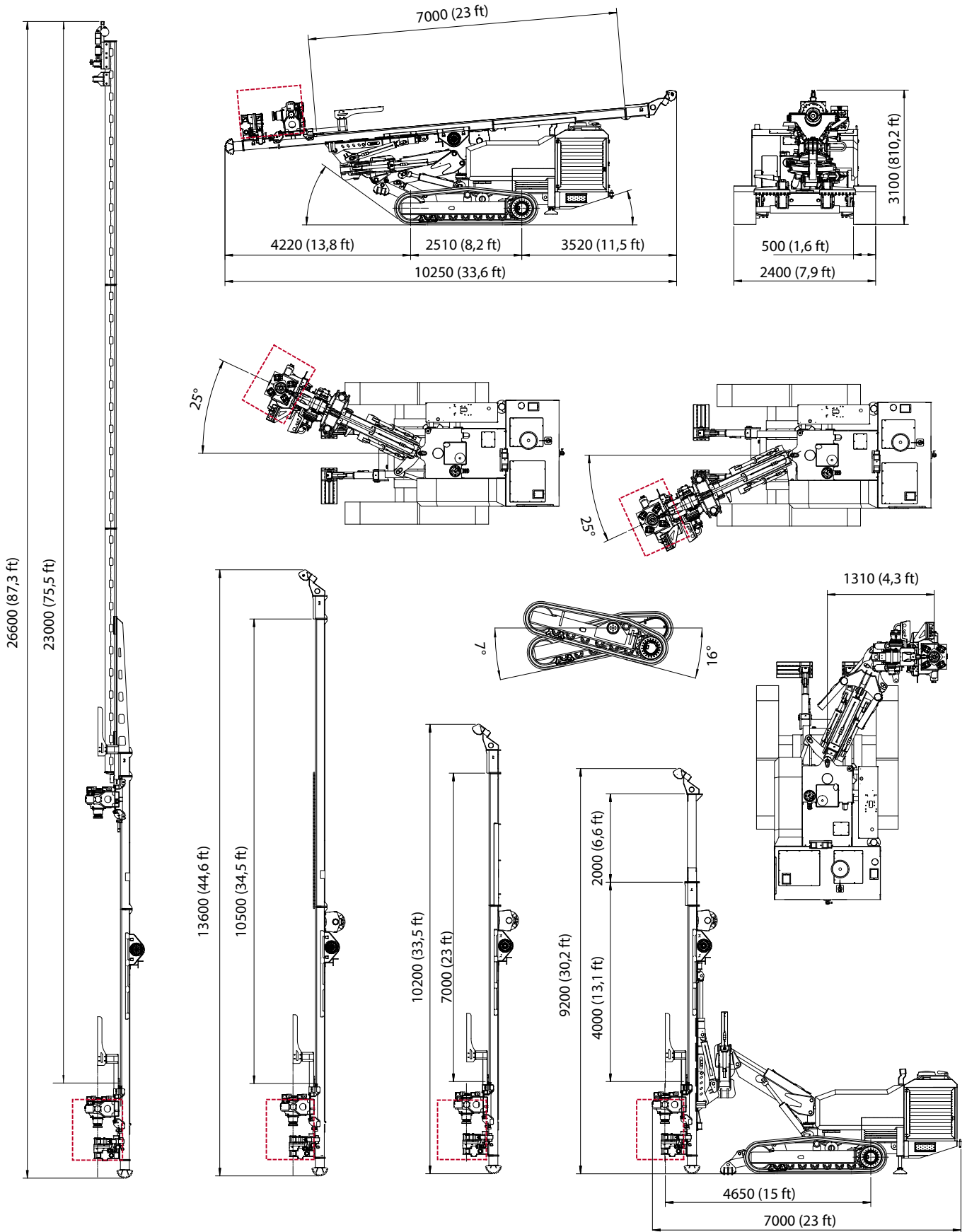

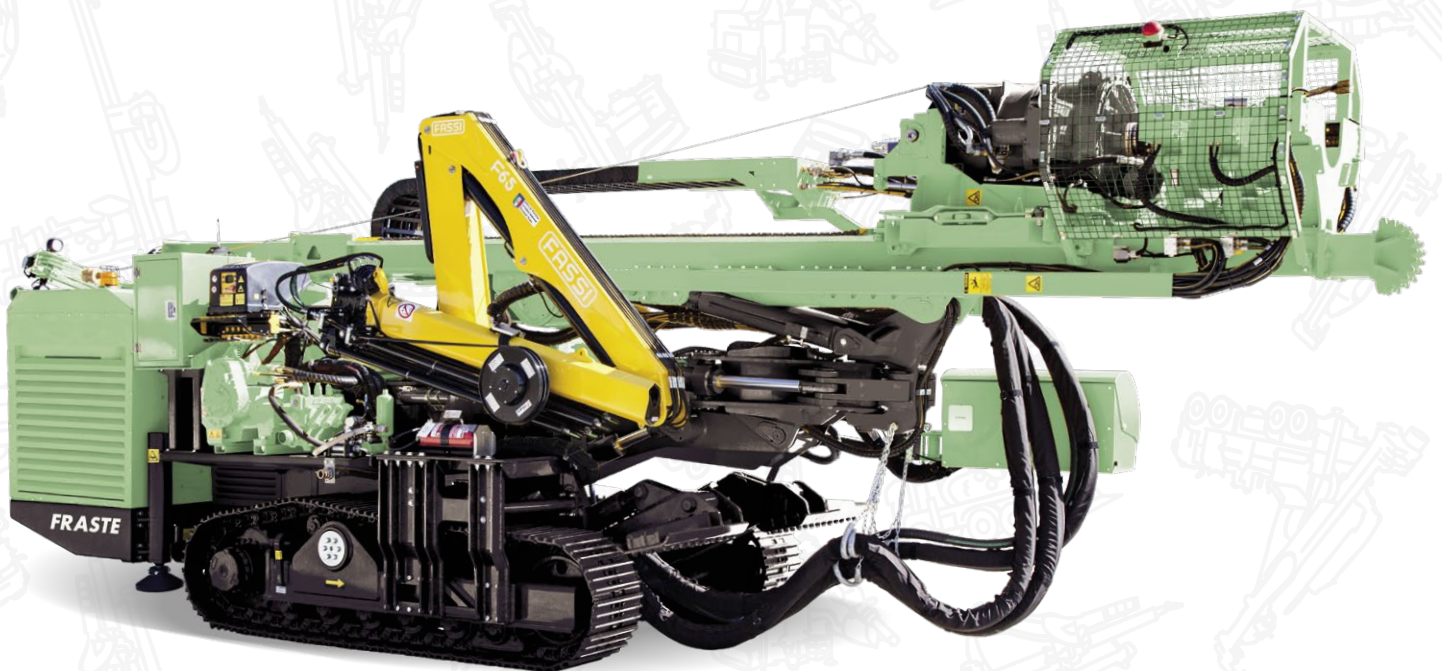

DATI TECNICI - TECHNICAL DATA - CARACTÉRISTIQUES TECHNIQUES - TECHNISCHE DATEN - DATOS TÉCNICOS



CARRO	UNDERCARRIAGE	CHENILLE	RAUPENFAHRZEUG	CARRO ORUGA		
Larghezza Min./Max.	Min./Max. width	Largeur Min./Max.	Min./Max. Gesamtbreite	Ancho total Min./Máx.	2400 mm (7,9 ft)	
Larghezza pattino	Pad width	Largeur patins	Kettenbreite	Ancho de patín de orugas	500 mm (1,6 ft)	
Passo cingolo	Wheelbase	Empattement	Fahrwerk Radstand	Paso entre ejes	2510 mm (8,2 ft)	
Pendenza max. superabile	Max. gradeability	Pente maxime	Max. Steighähigkeit	Pendiente máx. superable	50%	
Velocità di traslazione	Travelling speed	Vitesse de déplacement	Bewegung Geschwindigkeit	Velocidad de traslación	2 Km/h (1.2 mph)	
MOTORE DIESEL	DIESEL ENGINE	MOTEUR DIESEL	DIESELMOTOR	MOTOR DIESEL		
Potenza	Power	Puissance	Leistung	Potencia	CAT C7.1	CAT C7.1
					Tier 3	Tier 4 F
					205 Kw (275 Hp)	205 Kw (275 Hp)
Capacità serbatoio gasolio	Fuel tank capacity	Capacité réservoir diesel	Dieseltankinhalt	Capacidad depósito de combustible	230 l (60,7 gal)	
Capacità serbatoio olio idraulico	Oil tank capacity	Capacité réservoir d'huile	Öltankinhalt	Capacidad depósito de aceite hidráulico	460 l (120 gal)	
ANTENNA	MAST	MÂT	BOHRMAST	ANTENA		
Corsa testa di rotazione	Rotary head stroke	Course tête de rotation	Bohrmast Vorschub	Carrera cabezal de rotación	4000-7000-10500 mm (13,1- 23-34,5 ft)	
Tiro	Pull-up	Tir	Zugkraft	Tiro	10000 daN (22480 lbf)	
Spinta	Pull-down	Poussée	Andruck	Empuje	10000 daN (22480 lbf)	
Velocità salita - discesa	Pull-up - Pull down speed	Vitesse de montée - descente	Ausziehungsgeschwindigkeit - Vorschubgeschwindigkeit	Velocidad de extracción - de avance	40 m/min (125 ft/min)	
TESTA ROTANTE	ROTARY HEAD	TÊTE DE ROTATION	KRAFTDREHKOPF	CABEZAL DE ROTACIÓN		
R27						
Coppia max. 3 velocità	Max. torque 3 speeds	Couple max. 3 vitesses	Max. Drehmoment 3 Gänge	Fuerza de rotación máx. 3 velocidades	1460-1900-2400-2800 daNm (10800-14000-17700-20650 ft lbf)	
Velocità max. 3 velocità	Max. speed 3 speed	Vitesse maxime 3 vitesses	Max. Geschwindigkeit 3 Gang	Velocidad máx. 3 velocidades	190-145-115-100 rpm	
R26						
Coppia max. 2 velocità	Max. torque 2 speeds	Couple max. 2 vitesses	Max. Drehmoment 2 Gänge	Fuerza de rotación máx. 2 velocidades	1380-1730-2200-2900-3400 daNm (10200-12750-16250-21400-25100 ft lbf)	
Velocità max. 2 velocità	Max. speed 2 speed	Vitesse maxime 2 vitesses	Max. Geschwindigkeit 2 Gang	Velocidad máx. 2 velocidades	160-125-100-80-60 rpm	
MORSA	CLAMP	ÉTAU	ABFANGVORRICHTUNG	MORDAZA		
Morsa di bloccaggio Ø	Clamp Ø	Étau Ø	Abfanvorrichtung Ø	Mordaza Ø	60-365 mm (2,4"-14,4") 90-420 mm (3,5"-16,5")	
Forza di chiusura	Clamping force	Force de serrage	Klemmkraft	Fuerza de cierre	18000 daN (40465 lbf)	
Coppia svitamento	Break-out torque	Couple de deserrage	Ausdrehungsmoment	Fuerza de giro	5400 daNm (39800 ft lbf)	
Regolazione pressione massima	Max. pressure adjustment	Régulation pression max.	Max. Druck Regelung	Regulación de presión máx.	Standard	
PESO	WEIGHT	POIDS	GEWICHT	PESO	~21000/23000 Kg (~46300/50706 lb)	

I dati esposti sul presente catalogo possono variare senza preavviso - Specifications may change without notice - Ces caractéristiques peuvent être modifiées sans préavis
Technische Änderungen vorbehalten - Variaciones son premissibles sin previo aviso.

ACCESSORI - ACCESSORIES - ACCESSOIRES - ZUBEHÖR - ACCESORIOS

Caricatore idraulico per aste e tubi	Hydraulic rod & casing carousel	Système de chargement hydraulique des tiges et des tubes	Ladungssystem für Bohrstangen und Verrohrungen	Cargador hidráulico para barrena de perforación y de tubería casing	
Martello idraulico	Hydraulic drifter	Marteau hydraulique	Hydraulikhammer	Martillo hidráulico	
Verricello	Winch	Treuil	Winde	Cabrestante	3600 daN - 35 m/min (8093 lbf - 114 ft/min)
Verricello wire line	Wire line winch	Treuil wire line	Wire line Winde	Cabrestante wire line	
Pompa triplex	Triplex pump	Pompe triplex	Triplexpumpe	Bomba triplex	200 l/min - 70 bar (52 gpm - 1015 PSI)
Pompa schiuma	Foam pump	Pompe à mousse	Schaumpumpe	Bomba de espuma	34 l/min - 38 bar (9 gpm - 550 PSI)
Pompa lavaggio	Washing pump	Pompe pour lavage	Spülpumpe	Bomba limpiadora	15 l/min - 150 bar (4 gpm - 2175 PSI)
Lubrificatore di linea	Line lubricator	Graisseur de ligne	Linie-Schmiersystem	Lubricador de linea	8,5 l/min - (2,25 gpm)
Prolunga antenna	Mast extension	Extension du mat	Mastverlängerung	Prolongación de la antena	3000-6500 mm (9 ft 10"-21 ft 4")
Valvola idraulica aria	Hydraulic air valve	Valve d'air hydraulique	Luft-hydraulikventil	Valvula de aire hidráulica	2"
Gabbia di sicurezza	Safety cage	Cage de sécurité	Sicherheit Käfig	Jaula de seguridad	
Testa alta velocità per carotaggi	High speed rotary head for coring	Tête de rotation à haute vitesse pour carottage	Hoch Geschwindigkeit KDK für Kernbohrungen	Cabezal de alta velocidad para perforación de testigos	
Rotopercussione	Rotopercussion	Rotopercussion	Rotoperkussion	Rotopercusión	
Doppia testa	Double head	Double tête	Doppelkopf	Doble cabezal	
Jet grouting kit	Jet grouting kit	Jet grouting kit	Jet grouting kit	Jet grouting kit	24 mt (78,8 ft)
Cilindri estrattori	Pulling cylinders	Cylindres extracteurs	Abzieherzylinder	Cilindros extractores	
Registratore dati perforazione	Drilling data recorder	Enregistreur de données de forage	Bohr-Daten Schreiber	Grabadora de datos de perforación	
Illuminazione LED	LED Lighting	Éclairage LED	LED Beleuchtung	Iluminación LED	
Prefiltro aria motore ciclone	Air pre-filter cyclon engine	Pre-filtre d' air moteur cyclone	Zyklonmotor Luftvorfilter	Ciclon prelimpieza filtro de aire motor	
Pompa a vite	Screw pump	Pompe à vis	Schneckenpumpe	Bomba de tornillo	600 l/min - 12 bar (158 gpm - 174 PSI)
Inclinometro elettronico	Electronic inclinometer	Inclinomètre électronique	Elektronischer Neigungsmesser	Inclinómetro electrónico	
Pulsantiera via cavo	Cable remote control	Tableau des commandes avec cable	Kabelsteuerepult	Panel de mandos con cable	
Kit bilanciamento	Bit load control system	Kit de balancement	Andrück und Ruckhaltung stufenlos regulierung System	Sistema de ajuste del tiro-empuje	
Predisposizione idraulica esterna ausiliaria	Auxiliary hydraulic external prearrangement	Prédisposition hydraulique auxiliaire extérieure	Hydraulisch Hilfsextern Vorbereitung	Predisposicion hidráulica exterior auxiliar	
Gru	Crane	Grue	Krane	Grúa	62 kNm
Sovrapattini per cingoli in acciaio	Rubber pads for steel crawler carrier	Patin en caoutchouc pour chariot chenillé en acier	Gummischeuhe für Stahlraupen	Sobrepattinos para orugas en acero	